

# Rondotherm



by Britta v. Tasch

Prüfnummer | N° de contrôle | Control no. | Numero di prova **RRF-50 09 2149**

Prüfungen | Tests | Examinations | Esami

**DIN EN 13240:2001 /AC:2006 und DIN EN 13240:2001 /A2:2004/AC:2007 | 15a B-VG (A):**

**2. Stufe der 1. BImSchV Deutschlands, sowie die Luftreinhalte-Verordnung der Schweiz**

**Feuerungswerte<sup>1</sup> | Valeurs de combustion<sup>1</sup> | Combustion values<sup>1</sup> | Valori di combustione<sup>1</sup>**

<sup>1</sup>Bei 13% O<sub>2</sub> | Pour 13% de O<sub>2</sub> | At 13% O<sub>2</sub> | Con 13% O<sub>2</sub>

Holz | Bois |  
Wood | Legna.

<b>Nennwärmeleistung (NWL)</b>   Puissance calorifique nominale   Nominal thermal output   Potenza termica nominale	<b>Ø 1,2(10h) 7,5</b>	<b>kW</b>
<b>Wärmeleistungsbereich</b>   Domaine de puissance calorifique   Output range   Intervallo potenza termica	<b>7,6</b>	<b>kW</b>
<b>Abgasmassenstrom</b>   Flux massique des gaz de fumée   Flue gas mass flow rate   Flusso volumetrico dei fumi	<b>7,3</b>	<b>g/s</b>
<b>Abgasstutzentemperatur</b>   Température à la sortie de la fumée   Flue gas outlet temp.   Temperatura del condotto di scarico fumi	<b>280</b>	<b>°C</b>
<b>Mindestförderdruck bei NWL</b>   Pression minimum de refoulement à la puissance nominale   Min. supply pressure at nominal thermal output   Pressione minima di mandata a potenza nominale	<b>12</b>	<b>Pa</b>
<b>Wirkungsgrad</b>   Rendement   Efficiency   Efficienza	<b>81,2</b>	<b>%</b>
<b>Verbrennungsluftbedarf</b>   Besoin d'air de combustion   Combustion air requirement   Requisiti dell'aria di combustione	<b>29</b>	<b>m<sup>3</sup>/h</b>
<b>Feinstaub</b>   Poussières   Particulate matter   Polveri fini	<b>29</b>	<b>mg/Nm<sup>3</sup></b>
<b>CO-Gehalt</b>   Teneur en CO   CO content   Contenuto CO	<b>1125</b>	<b>mg/Nm<sup>3</sup></b>
<b>Mittlerer CO<sub>2</sub>-Gehalt</b>   Contenu moyen en CO <sub>2</sub>   Average CO <sub>2</sub> content   Contenuto medio di CO <sub>2</sub>	<b>9,2</b>	<b>%</b>
<b>OGC</b>	<b>68</b>	<b>mg/Nm<sup>3</sup></b>
<b>NO<sub>x</sub></b>	<b>124</b>	<b>mg/Nm<sup>3</sup></b>
<b>Raumheizvermögen (abhängig von der Isolierung des Hauses in m<sup>2</sup>)</b>   Volume de chauffage de la pièce (en fonction de l'isolation de la maison, en m <sup>2</sup> )   Space heating capacity (depending on the insulation of the house in m <sup>2</sup> )   Capacità di riscaldamento dell'ambiente (a seconda dell'isolamento della casa in m <sup>2</sup> )	<b>25- 60</b>	<b>m<sup>2</sup></b>

**Maße & Gewicht** | Dimensions & poids | Dimensions & weight | Dimensioni & peso

**Maße in cm** | Dimension en cm | Dimensions in cm | Dimensioni in cm

<b>a</b>	<b>Höhe</b>   Hauteur   Height   Altezza	<b>155,5</b>
<b>b</b>	<b>Breite</b>   Largeur   Width   Larghezza	<b>54,5</b>
<b>c</b>	<b>Tiefe</b>   Profondeur   Depth   Profondità	<b>54,5</b>
<b>d</b>	<b>Höhe des Rauchrohranschlusses</b>   Hauteur du raccordement de fumée   Height of the flue pipe connection   Altezza del collegamento del gas di scarico	<b>137,5</b>
<b>e</b>	<b>Distanz Ofenrückwand / Rauchrohrmitte</b>   Distances arrière du poêle / centre conduit de fumée   Distance from rear wall of stove / centre of flue pipe   Distanza parete posteriore della stufa / centro della canna fumaria	<b>27,25</b>
<b>f</b>	<b>Höhe des Verbrennungsluftanschlusses</b>   Hauteur de la prise d'air de combustion   Height of combustion air connection   Altezza dell'attacco dell'aria di combustione	<b>14</b>
<b>g</b>	<b>Distanz Ofenrückwand / Verbrennungsluftstutzen unten</b>   Distance entre la paroi arrière du four / le raccord d'air de combustion en bas   Distance between rear wall of stove / combustion air connection at bottom   Distanza tra la parete posteriore della stufa e il raccordo inferiore dell'aria di scarico	<b>27,25</b>
	<b>Rauchgasanschluss</b>   Raccordement de fumée   Connection for flue gas   Connessione per i gas di scarico	<b>Ø 15</b>
	<b>Verbrennungsluftanschluss</b>   Prise d'air de combustion   Connection for combustion air   Collegamento per l'aria di combustione	<b>Ø 10</b>
	<b>Feuerraum (H x B x T)</b>   Foyer (H x L x P)   Fire pit (H x W x D)   Fossa antincendio (A x L x P)	<b>49 x 32 x 44</b>
	<b>Feuermulde (B x T)</b>   Bac à feu (L x P)   Fire bowl (W x D)   Ciotola per il fuoco (L x P)	<b>32 x 32</b>
	<b>Gewicht</b>   poids   weight   peso	<b>392 kg</b>

# Rondotherm

CERA  
DESIGN

by  
Bräta v. Jasch

Ansichten | Vues de | Views of | Visualizzazioni

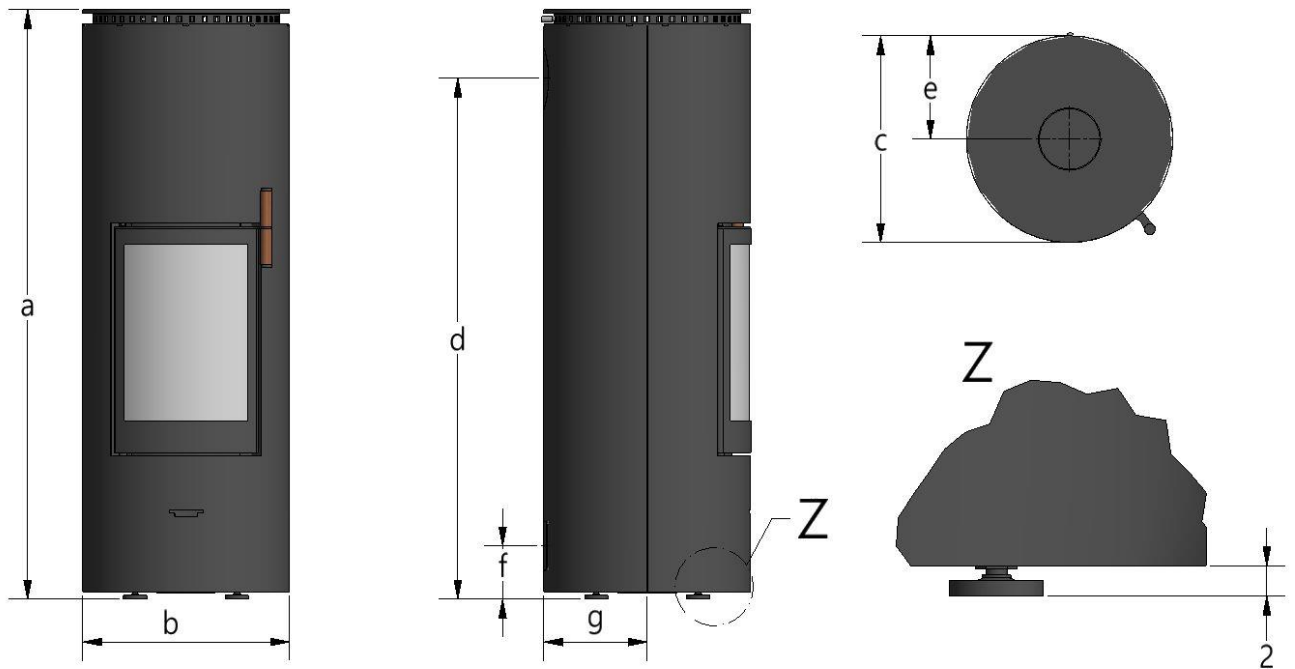

Sicherheitsabstände | Distances de sécurité | Safety Distances | Distanze di sicurezza

Maße in cm | Dimensions en cm | Dimensions in cm | Dimensioni in cm

**Abstände zu brennbaren Materialien**  
Distances aux matériaux combustibles  
Distances to combustible materials  
Distanze da materiali combustibili

**Größe der Bodenplatte**  
Taille de la plaque de sol  
Size of floor plate  
Dimensione della piastra di base

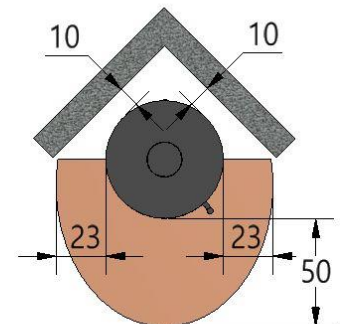
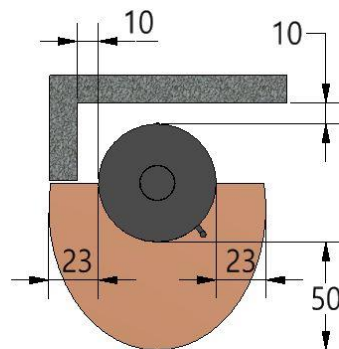
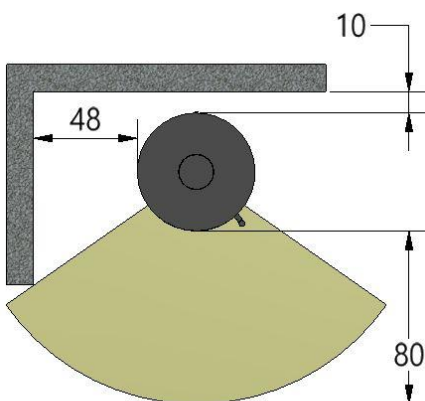

**Bitte beachten Sie zusätzlich die Hinweise in der Bedienungsanleitung!**

Veuillez également noter les informations contenues dans le mode d'emploi!

Please also note the information in the instructions for use!

Si prega di osservare anche le informazioni contenute nelle istruzioni per l'uso.

Technische Änderungen vorbehalten | Sous réserve de modifications techniques | Subject to technical changes |

Soggetto a modifiche tecniche